

GRID LOCATION
E-D/3
E-D/7
E-D/7
E-D/4-3
D-C/4-3
D-C/5-4
E-D/5-4
E-D/3

### BILL OF MATERIAL

REV	LINE #	ADVANCE MILL #	QTY TOTAL	PC MARK	MINOR MARK	DESCRIPTION	LENGTH	STEEL GRADE	REMARKS	WEIGHT TOTAL
			8	105		EMBED PLATE				
			8		105	PL 1/2" X 19"	1' 10"	A36		474.18
			120		m102	#6 REBAR	2' 2 1/2"	A706		358.71

FIELD BOLTS

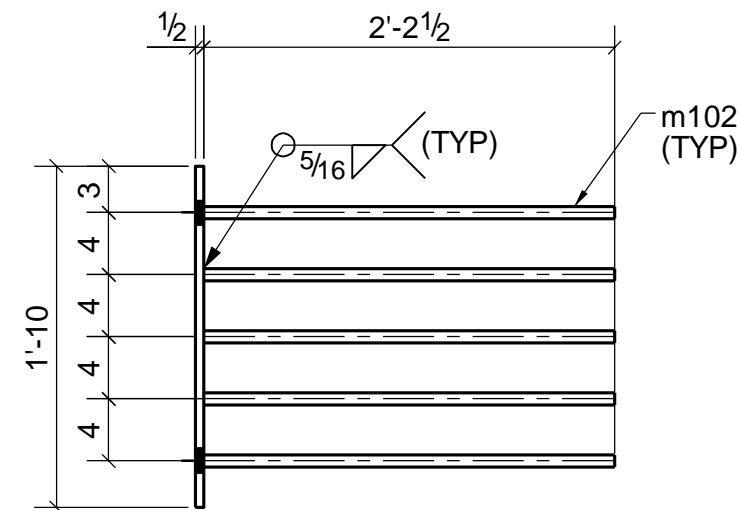
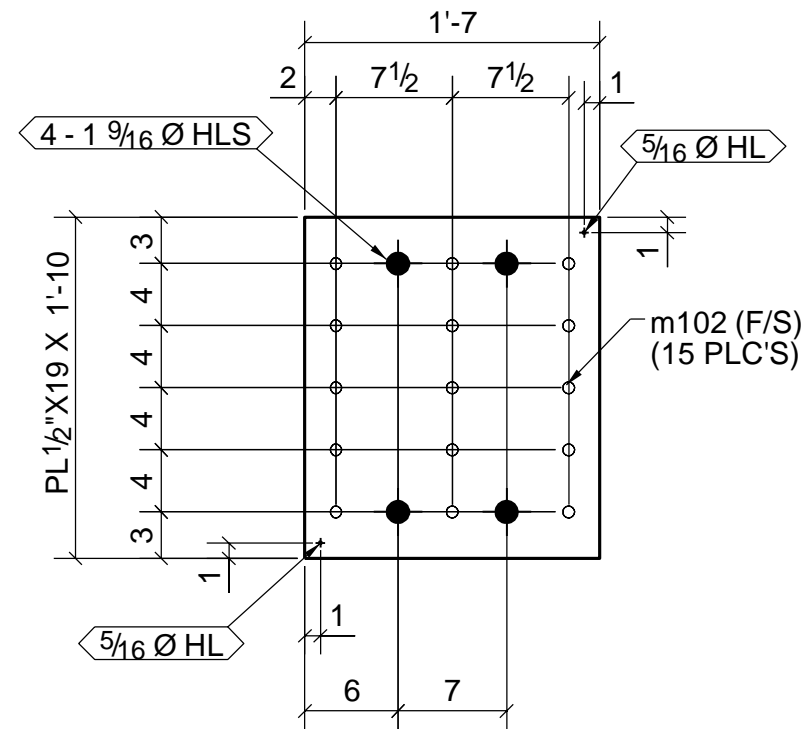

**8 ~ EMBED PLATES ~ 105**  
(8 @ AB101 & AB102)

0	06/13/2018	FOR FABRICATION	
A	06/13/2018	FOR APPRIVAL	
REV	DATE	DESCRIPTION	BY

PRIMER: NO PAINT  
 HOLES: 13/16 U.N.O.      PREP: SSPC-SP3  
 BOLTS: - -      WELDS:



PROJECT: SEA118 RAD  
 PROJECT #: SRAD-822  
 ADDRESS: 15110 NE 95TH STREET  
 LOCATION: Redmond, WA 98052

DRAWN BY: MEA      CHECKED BY: SDK      REF DWG: E1001 THRU E1020

JOB COLOR: GREEN  
 CUT BY: \_\_\_\_\_  
 LAYOUT BY: \_\_\_\_\_  
 FAB BY: \_\_\_\_\_  
 CHECKED BY: \_\_\_\_\_

STATUS:  
 FOR FABRICATION  
 DRAWING NO.  
**105**