

A-A

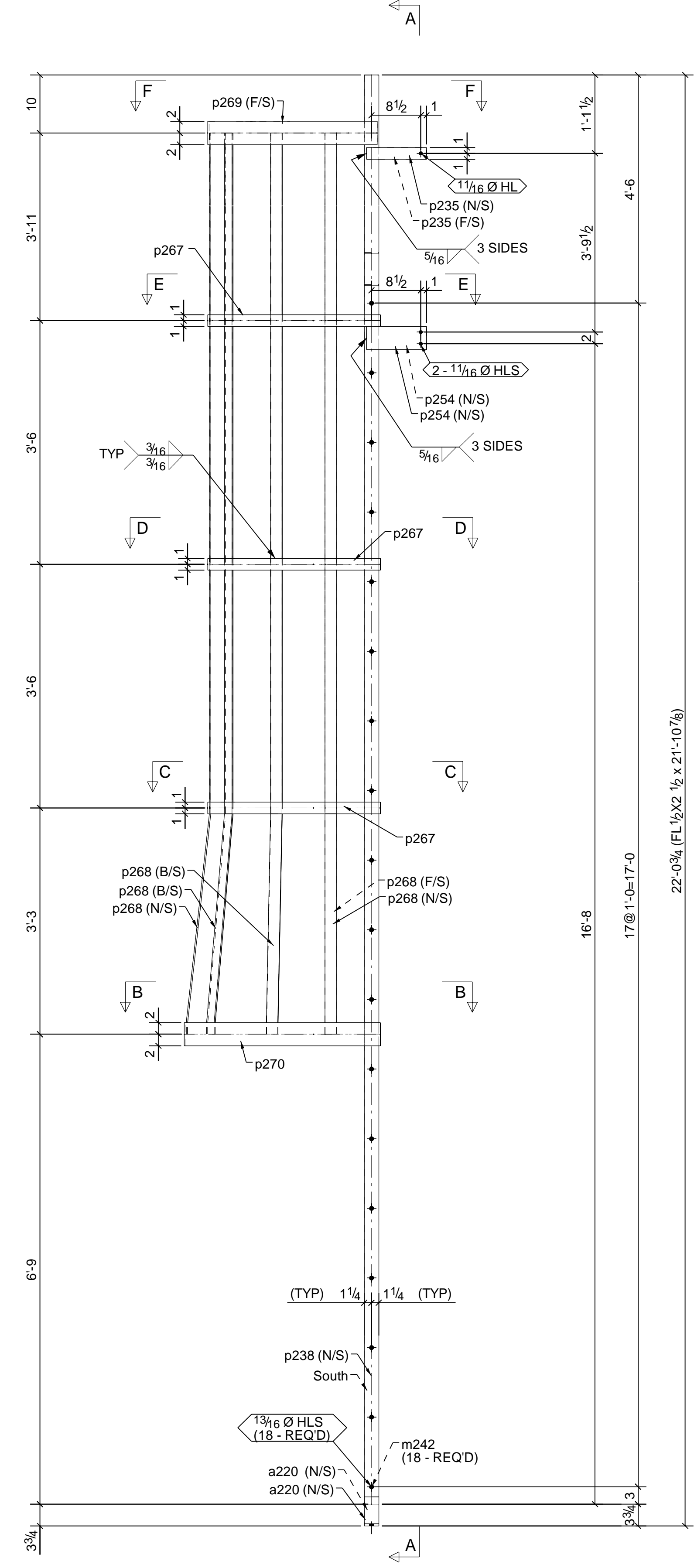

ONE - LADDER - 437LD1

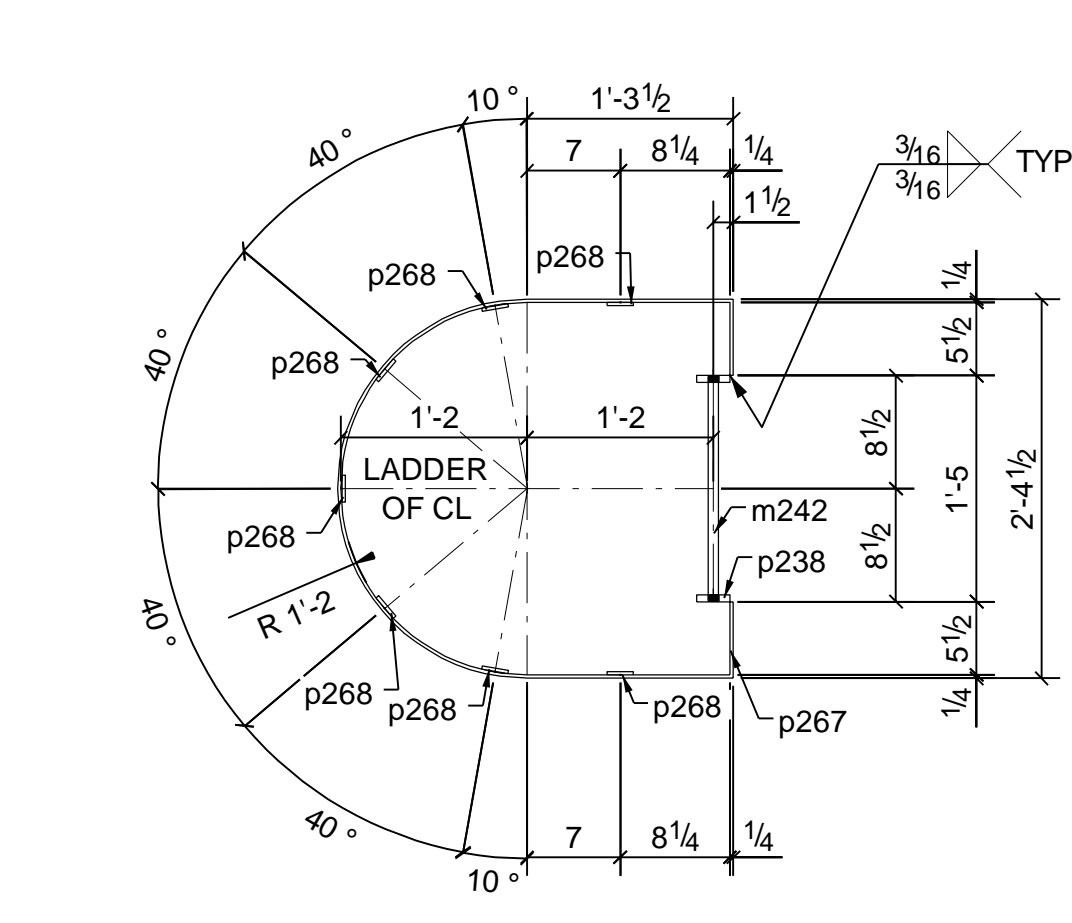

SECTION D - D

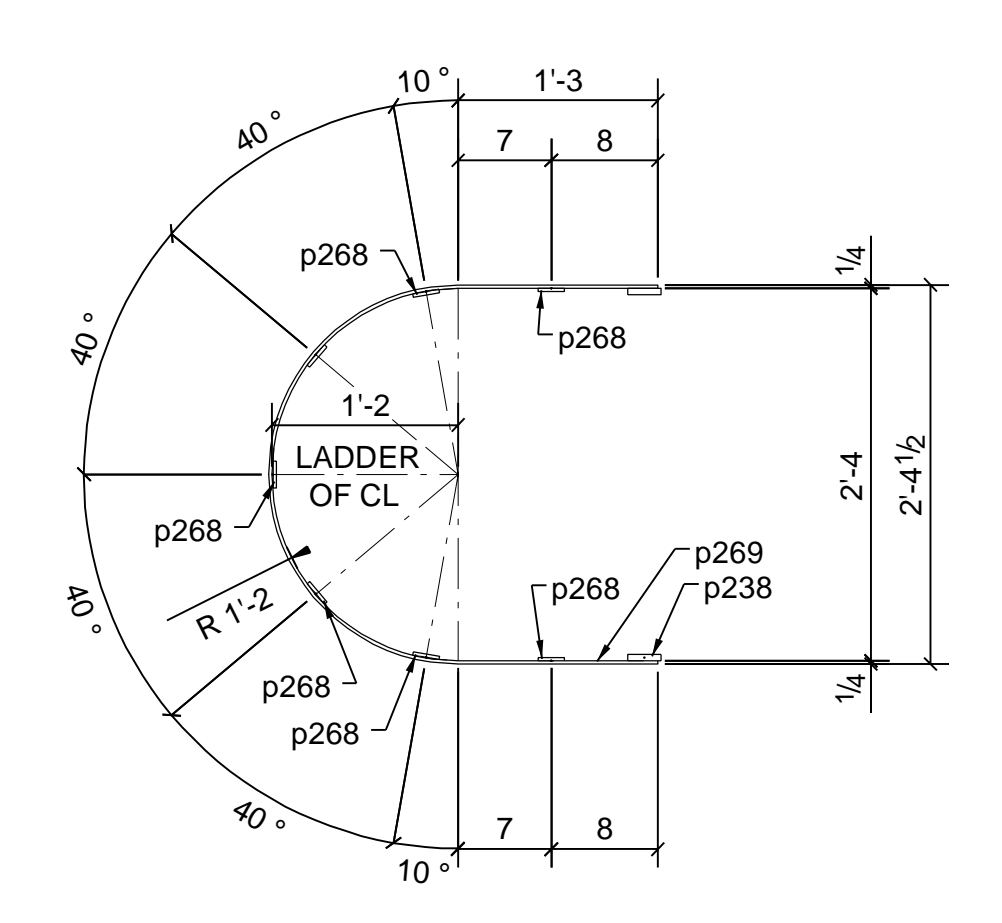

SECTION F - F

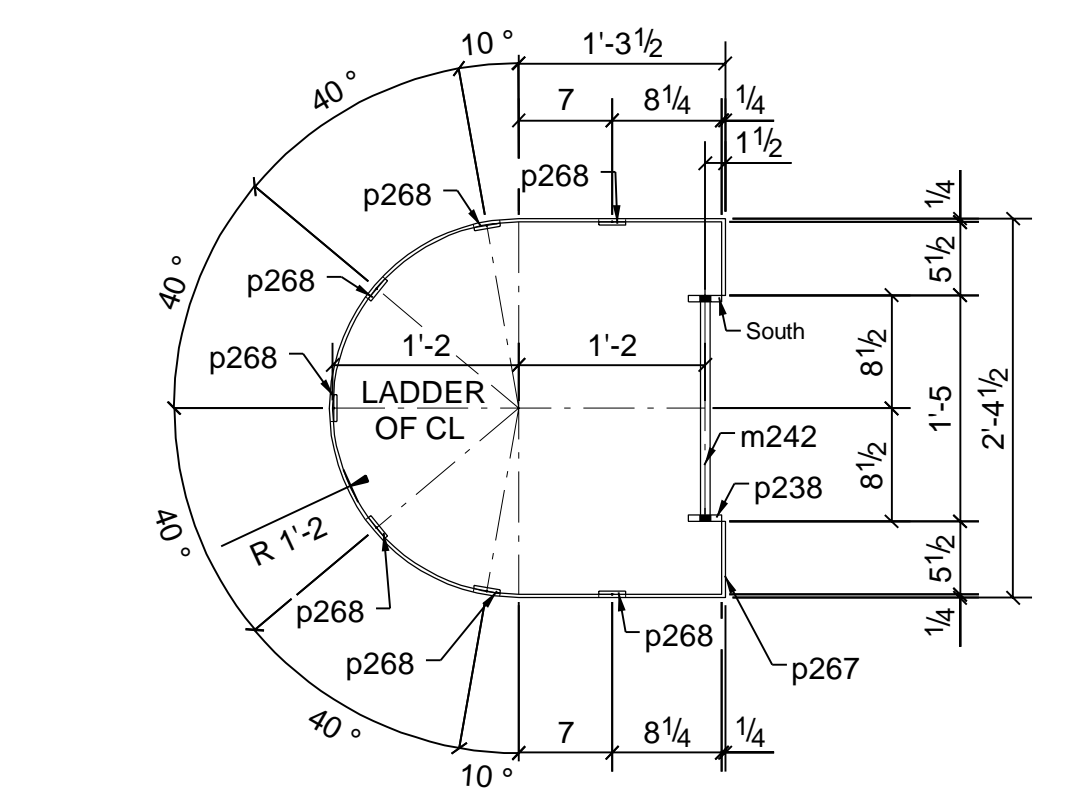

SECTION C - C

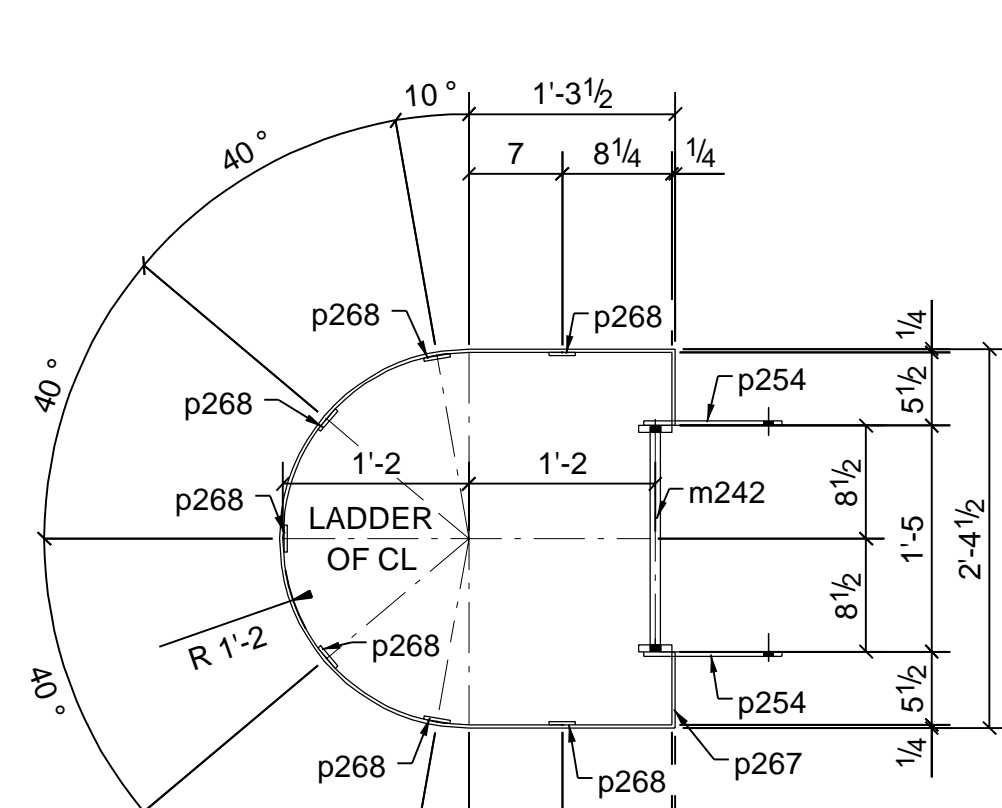

SECTION E - E

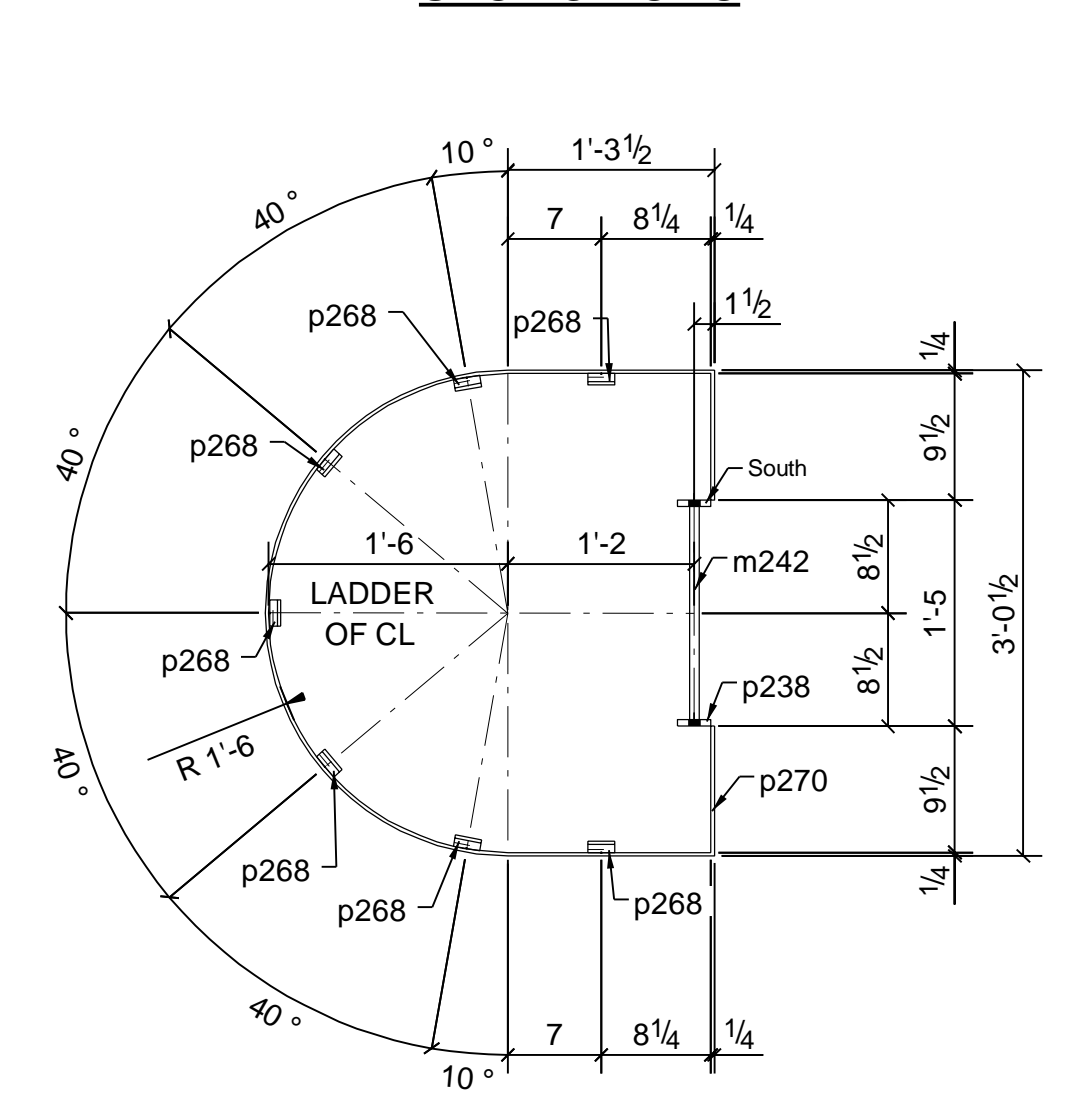

SECTION B - B

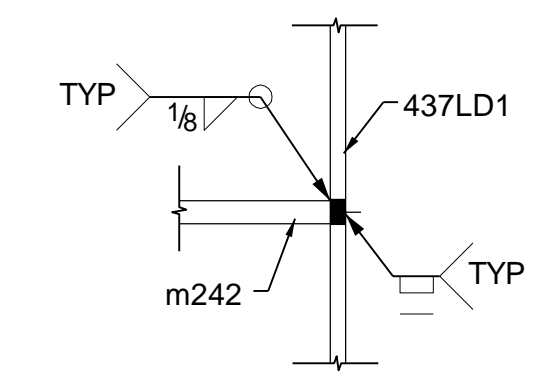

DETAIL 1

BILL OF MATERIAL

MARK	NO. REQ'D	DESCRIPTION	LENGTH		REMARKS	WEIGHT	
			FT.	IN.			
1	437LD1	ONE	FL1/2"x2 1/2"	<A36>	21	10 7/8"	93
2	a220	2	L5X3X3/8		0	0'-2 1/2"	2
3	m242	18	ROD3/4"		1	4 3/4"	2
4	p235	2	FL3/8"x2"		0	0'-10 3/8"	2
5	p238	1	FL1/2"x2 1/2"		21	10 7/8"	93
6	p254	2	FL3/8"x4"		0	0'-10 3/8"	4
7	p267	3	FL1/4"x2"		7	1 7/8"	12
8	p268	7	FL1/4"x2"		14	2 3/16"	24
9	p269	1	FL1/4"x4"		6	2 3/8"	21
10	p270	1	FL1/4"x4"		8	10 7/16"	30
11							
12						TOTAL WEIGHT THIS DWG:	285 lbs
13							
14							
15							
16							
17							
18							
19							
20							
21							
22							
23							
24							
25							
26							
27							
28							
29							
30							
31							
32						FIELD BOLT LIST	
33							
34	8		5/8" \varnothing A325 GALV		1 3/4"	W/N&W	
35							
36							
37							
38							
39							
40							
41							
42							
43							
44							
45							
46							
47							
48							
49							
50							