

BILL OF MATERIAL

SHIP	MARK	NO. PCS.	DESCRIPTION	LENGTH		FAB MARK	MATL GRADE	ADV. BILL P-L	NOTES
				FT.	IN.				
8004	S8004	1	STRINGER						
			C12X20.7	12	11 5/16"		A36		
		22	L1-1/2X1-1/2X3/16	0	8"		A36		
		1	L2X2X1/4	2	11"		A36		
		1	C12X20.7	13	6 9/16"		A36		
		1	C12X20.7	3	2 5/16"		A36		
		1	C12X20.7	0	6 3/4"		A36		
		1	FL3/8"X3 1/2"	0	9"		A36		
		1	FL3/8"X3 1/2"	0	6"		A36		
		2	FL3/8"X2 1/2"	1	1 1/16"		A36		
		1	FL1/4"X3"	0	9 1/8"		A36		
		2	FL1/4"X3"	0	5 5/16"		A36		
		2	FL1/4"X3"	0	6 3/4"		A36		
		1	SHT12GAX14 3/8"	3	4"		A36		
		11	SHT12GAX22 5/16"	3	4"		A36		
		1	SHT12GAX4 15/16"	3	4"		A36		

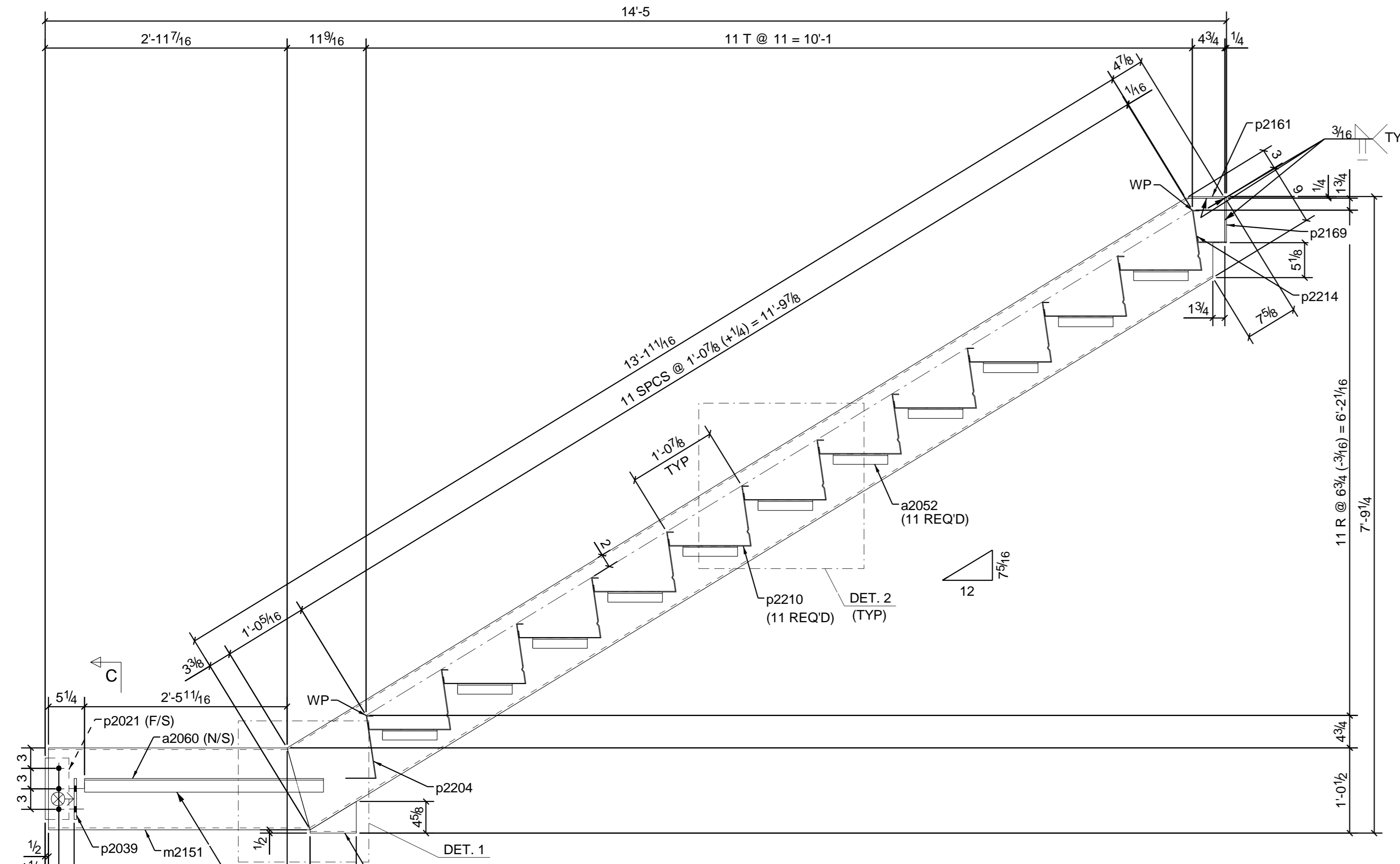

SECTION A - A

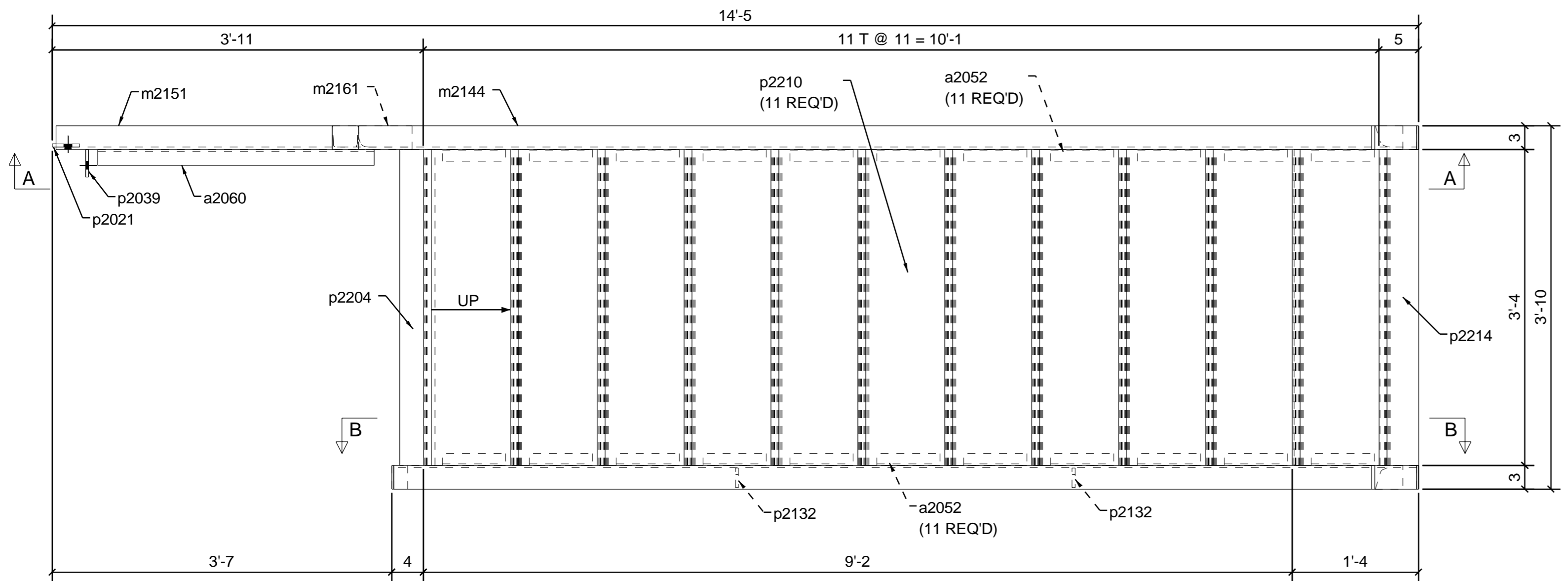
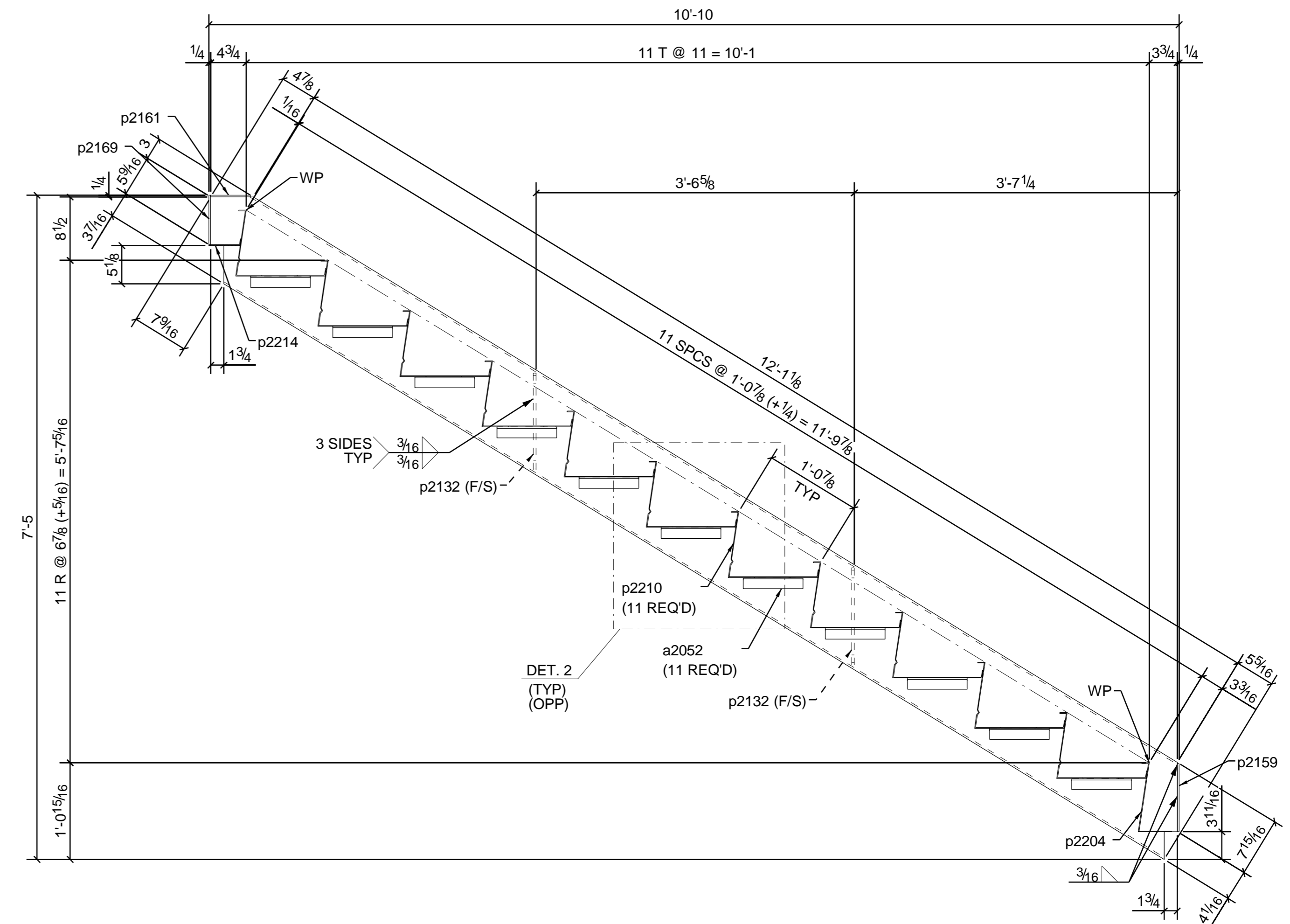

SECTION B - B

ONE - STRINGER - S8004

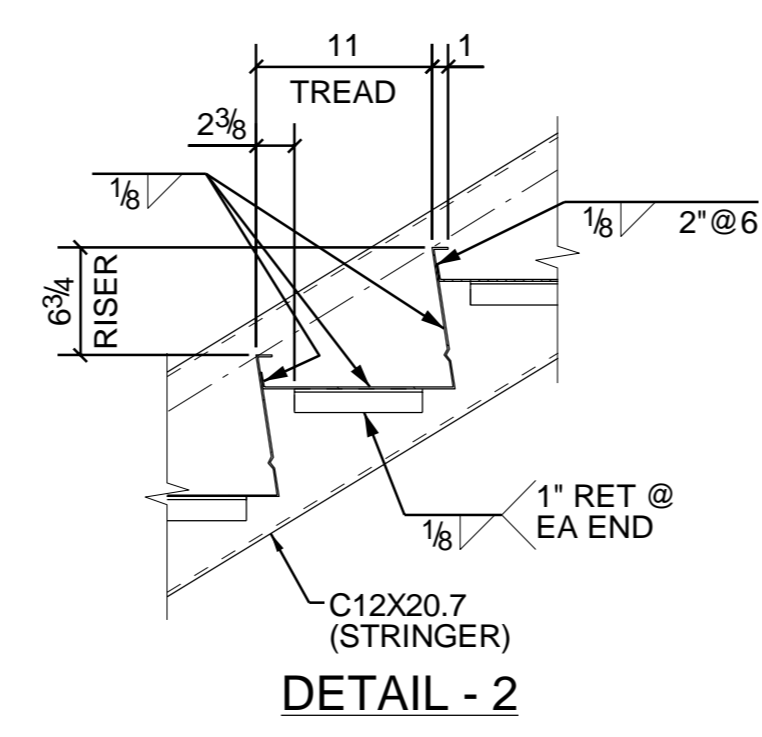
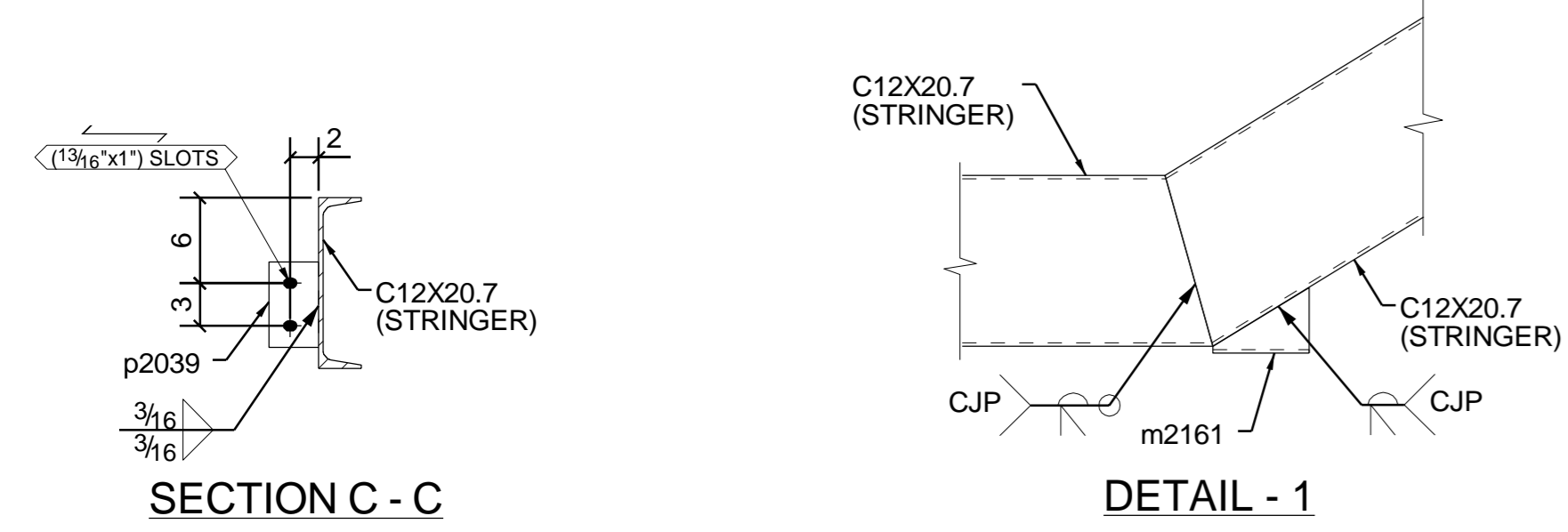

DETAIL - 2

REF. DWG.: M1001 THRU M1003

APPROVAL AND INFORMATION LOG					
SUBMITTED	FOR	REV.#	RETURNED	MARKED	BACK
05/22/2018	For Fabrication	0			
DRAWING TITLE					
JOB NAME:					
CUSTOMER:					
FINISH:				CONT. NO.	
PAINT: HIDE-GRID				DRAWING	
HOLES: 13/16Ø				NO. STRINGER 0	